

Portable Ultrasonic Flow Measurement of Liquids

Portable instrument for non-invasive, quick ultrasonic flow measurement with clamp-on technology

Features

- Non-invasive measurement using the clamp-on technology for precise, bi-directional and highly dynamic flow measurements
- Portable, easy-to-use flow transmitter with 2 flow channels, multiple inputs & outputs and an integrated data logger with a serial interface
- Automatic loading of calibration data and transducer detection, reduces set-up time and provides precise, long-term stable results
- Li-Ion battery provides up to 14 hours of measurement
- Transducers available for a wide range of inner pipe diameters (0.25 to 256 in) and fluid temperatures in the range of (-40 to +752 °F), applications down to -276 °F possible
- Transducers resistant to dust and humidity
- Probe for wall thickness measurement available
- Ruggedized housing is resistant against water, dust, and oil
- Robust, water-tight (NEMA 6) transport case with comprehensive accessories
- HybridTrek mode automatically switches between transit time and NoiseTrek methods of measurement when high particulate flows are encountered
- QuickFix for fast mounting of the transmitter in difficult conditions



FLUXUS F601 supported by handle



Measurement with transducers mounted by fastening shoes and flow transmitter fixed to the pipe by the QuickFix pipe mounting fixture

Applications

- Designed for the following industries:
 - Chemical industry
 - Water and wastewater industry
 - Oil and gas industry
 - Cooling systems and air conditioners
 - Facility management
 - Aviation industry



Measurement equipment in transport case

Table of Contents

Function	3
Measurement Principle	3
Calculation of Volumetric Flow Rate	3
Number of Sound Paths.....	4
Typical Measurement Setup	5
Flow Transmitter	6
Technical Data	6
Dimensions	8
Standard Scope of Supply	9
Connection of Adapters	10
Example for the Equipment of a Transport Case	11
Transducers	12
Transducer Selection	12
Transducer Order Codes	13
Technical Data	14
Transducer Mounting Fixtures	17
Coupling Materials for Transducers	21
Connection Systems	22
Transducer Cables	22
Temperature Probes (optional)	23
Wall Thickness Probe (optional)	24

Function

Measurement Principle

Transit Time Difference Principle

In order to measure the flow of a medium in a pipe, ultrasonic signals are used which employ the transit time difference principle. Ultrasonic signals are emitted by a transducer installed on one side of the pipe, reflected by the opposite pipe wall, and received by a second transducer. These signals are emitted alternately in the flow direction and then against it.

As the medium in which the signals propagate is flowing, the transit time of the ultrasonic signals in the flow direction is shorter than against the flow direction.

The transit time difference, Δt , is measured and allows the transmitter to determine the average flow velocity along the propagation path of the ultrasonic signals. A flow profile correction is then performed in order to obtain the area averaged flow velocity, which is proportional to the volumetric flow rate.

Two integrated microprocessors control the entire measurement process. This allows the transmitter to remove disturbance signals, and to check each received ultrasonic wave for its validity which reduces noise.

HybridTrek

If gaseous or solid content in the medium increases occasionally during measurement, a measurement with the transit time difference principle is no longer possible. NoiseTrek mode will then be selected by the transmitter. This measurement method allows the transmitter to achieve a stable measurement even with high gaseous or solid content.

The transmitter can switch automatically between transit time and NoiseTrek modes without any changes to the measurement setup.

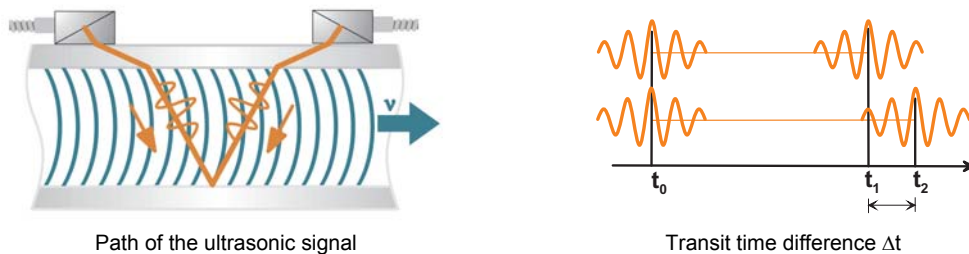

Calculation of Volumetric Flow Rate

$$Q = k_{Re} \cdot A \cdot k_a \cdot \Delta t / (2 \cdot t_{fl})$$

where:

- Q - volumetric flow rate
- k_{Re} - fluid mechanics calibration factor
- A - cross-sectional area of the pipe
- k_a - acoustical calibration factor
- Δt - transit time difference
- t_{fl} - transit time in the medium

Number of Sound Paths

The number of sound paths is the number of transits of the ultrasonic signal through the medium in the pipe. Depending on the number of sound paths, the following methods of installation exist:

- **reflect mode**
The number of sound paths is even. Both of the transducers are mounted on the same side of the pipe. Correct positioning of the transducers is easier.
- **diagonal mode**
The number of sound paths is odd. Both of the transducers are mounted on opposite sides of the pipe.
- **direct mode**
Diagonal mode with 1 sound path. This should be used in the case of high signal attenuation by the medium, pipe or coatings.

The preferred method of installation depends on the application. While increasing the number of sound paths increases the accuracy of the measurement, signal attenuation increases as well. The optimum number of sound paths for the parameters of the application can be determined automatically by the transmitter.

As the transducers can be mounted with the supplied transducer mounting fixture in reflect or diagonal mode, the number of sound paths can be adjusted optimally for almost any application.

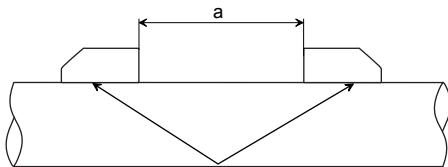

Reflect mode, number of sound paths: 2

a - transducer distance

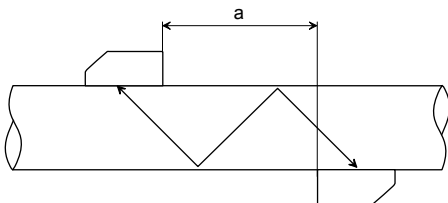

Diagonal mode, number of sound paths: 3

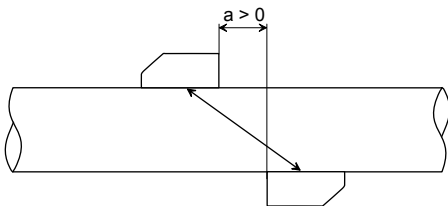

Direct mode , number of sound paths: 1

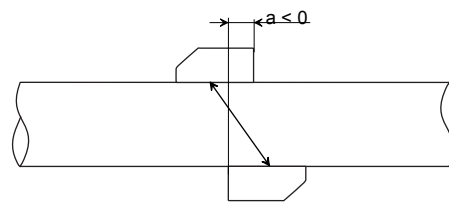

Direct mode , number of sound paths: 1,
negative transducer distance

Typical Measurement Setup

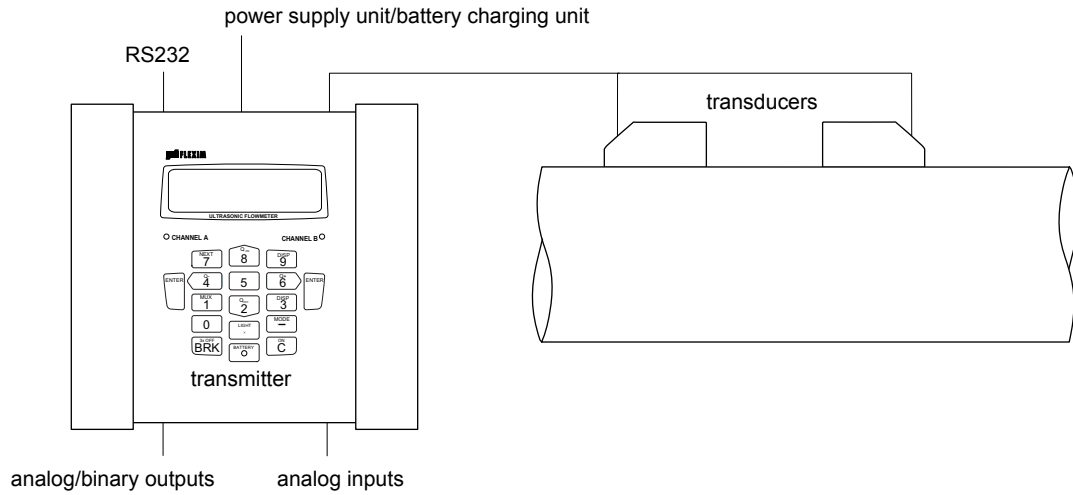

Example of a measurement setup in reflect mode

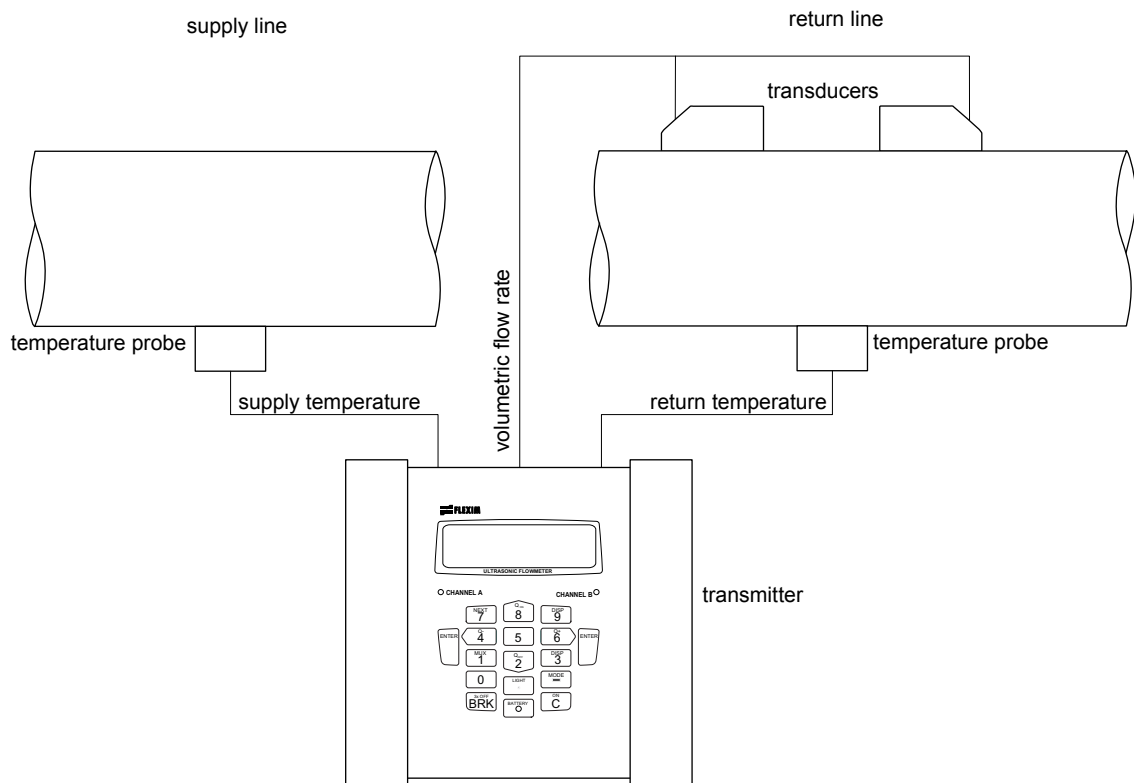

Example of a heat flow measurement

Flow Transmitter

Technical Data

FLUXUS	F601
design	portable
	
measurement	
measuring principle	transit time difference correlation principle, automatic NoiseTrek selection for measurements with high gaseous or solid content
flow velocity	0.03 to 82 ft/s
repeatability	0.15 % of reading \pm 0.03 ft/s
medium	all acoustically conductive liquids with < 10 % gaseous or solid content by volume (transit time difference principle)
temperature compensation	corresponding to the recommendations in ANSI/ASME MFC-5M-1985
accuracy ¹	
with standard calibration	\pm 1.6 % of reading \pm 0.03 ft/s
with extended calibration (optional)	\pm 1.2 % of reading \pm 0.03 ft/s
with field calibration ²	\pm 0.5 % of reading \pm 0.03 ft/s
flow transmitter	
power supply	100 to 240 V/50 to 60 Hz (power supply unit), 10.5 to 15 V DC (socket at transmitter) or integrated battery
battery	Li-Ion, 7.2 V/4.5 Ah operating time (without outputs, inputs and backlight): > 14 h
power consumption	< 6 W
number of flow measuring channels	2
signal attenuation	0 to 100 s, adjustable
measuring cycle (1 channel)	100 to 1000 Hz
response time	1 s (1 channel), optional: 70 ms
housing material	PA, TPE, AutoTex, stainless steel
degree of protection	NEMA 4
weight	4.2 lb
fixation	QuickFix pipe mounting fixture
operating temperature	14 to 140 °F
display	2 x 16 characters, dot matrix, backlit
menu language	English, German, French, Dutch, Spanish
measuring functions	
physical quantities	volumetric flow rate, mass flow rate, flow velocity, heat flow (if temperature inputs are installed)
totalizers	volume, mass, optional: heat quantity
calculation functions	average, difference, sum
diagnostic functions	sound velocity, signal amplitude, SNR, SCNR, standard deviation of amplitudes and transit times
data logger	
loggable values	all physical quantities, totalized values and diagnostic values
capacity	> 100 000 measured values

¹ for transit time difference principle, reference conditions and $v > 0.49$ ft/s

² reference uncertainty < 0.2 %

FLUXUS	F601
communication	
interface	RS232/USB
serial data kit	
software (all Windows™ versions)	- FluxData: download of measured data, graphical presentation, conversion to other formats (e.g. for Excel™) - FluxKoeff: creating medium data sets
cable	RS232
adapter	RS232 - USB
transport case	
dimensions	19.7 x 15.7 x 7.5 in
outputs	
	The outputs are galvanically isolated from the transmitter.
number	see standard scope of supply on page 9, max. on request
accessories	output adapter (if number of outputs > 4)
current output	
range	0/4 to 20 mA
accuracy	0.1 % of reading ±15 µA
active output	$R_{ext} < 200 \Omega$
passive output	$U_{ext} = 4 \text{ to } 16 \text{ V}$, dependent on R_{ext} $R_{ext} < 500 \Omega$
frequency output	
range	0 to 5 kHz
open collector	24 V/4 mA
binary output	
optorelay	26 V/100 mA
binary output as alarm output - functions	limit, change of flow direction or error
binary output as pulse output - pulse value - pulse width	0.01 to 1000 units 1 to 1000 ms
inputs	
	The inputs are galvanically isolated from the transmitter.
number	see standard scope of supply on page 9, max. 4
accessories	input adapter (if number of inputs > 2)
temperature input	
designation	Pt100/Pt1000
connection	4-wire
range	-238 to +1040 °F
resolution	0.01 K
accuracy	±0.01 % of reading ±0.03 K
current input	
accuracy	0.1 % of reading ±10 µA
passive input - range	$R_i = 50 \Omega$, $P_i < 0.3 \text{ W}$ -20 to +20 mA
voltage input	
range	0 to 1 V
accuracy	0.1 % of reading ±1 mV
internal resistance	$R_i = 1 \text{ M}\Omega$

Dimensions

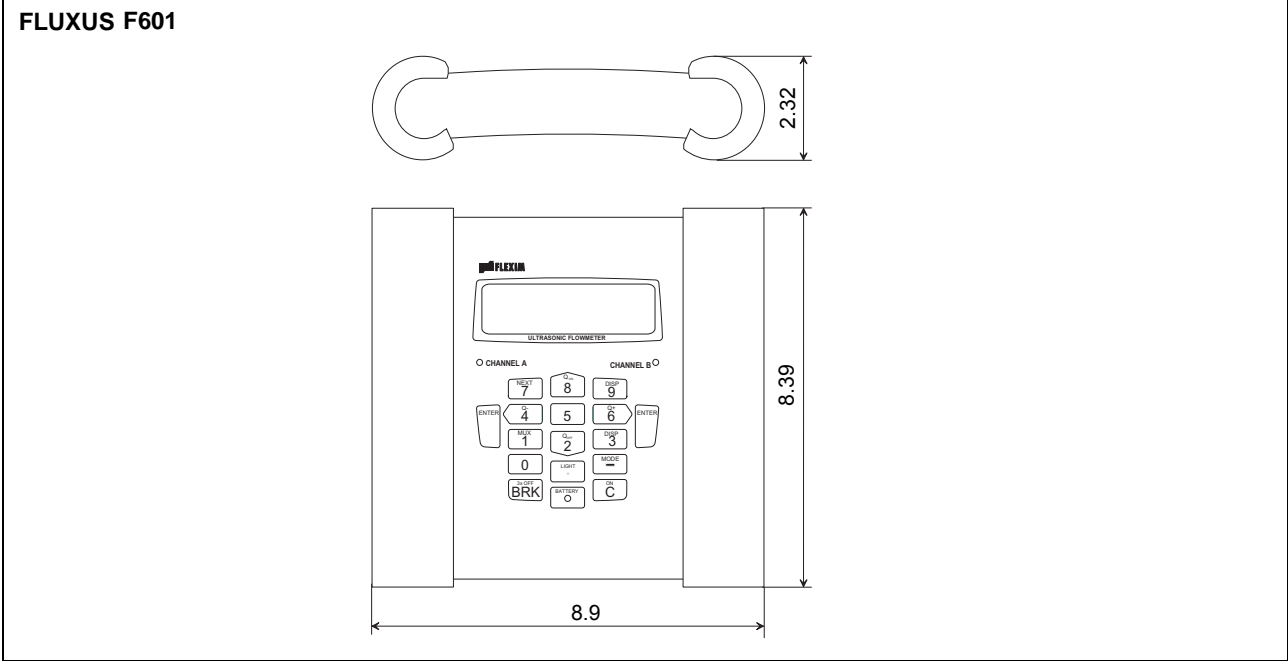

in inch

Standard Scope of Supply

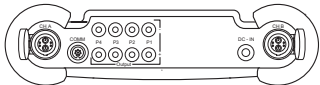
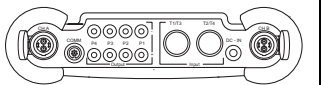
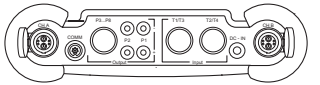
	F601 Standard	F601 Energy	F601 Multifunctional
application	all flow measurements on liquids, e.g. modeling of pump curves	including energy calculator for BTU and heat measurements	sophisticated measuring tasks, e.g. temporary substitute of other flowmeters with compensation of input quantities (e.g. density, viscosity) and simultaneous measured value output
outputs			
passive current output	2	2	4
binary output	2	2	2
inputs			
temperature input	-	2	2
passive current input	-	-	2
accessories			
transport case	x	x	x
power supply unit, power cable	x	x	x
battery	x	x	x
output adapter	-	-	x
input adapter	-	-	2
adapter for voltage or current inputs	-	-	2
QuickFix pipe mounting fixture for transmitter	x	x	x
serial data kit	x	x	x
measuring tape	x	x	x
user manual, Quick Start Guide	x	x	x
connector board at the upper side of the transmitter			

Connection of Adapters

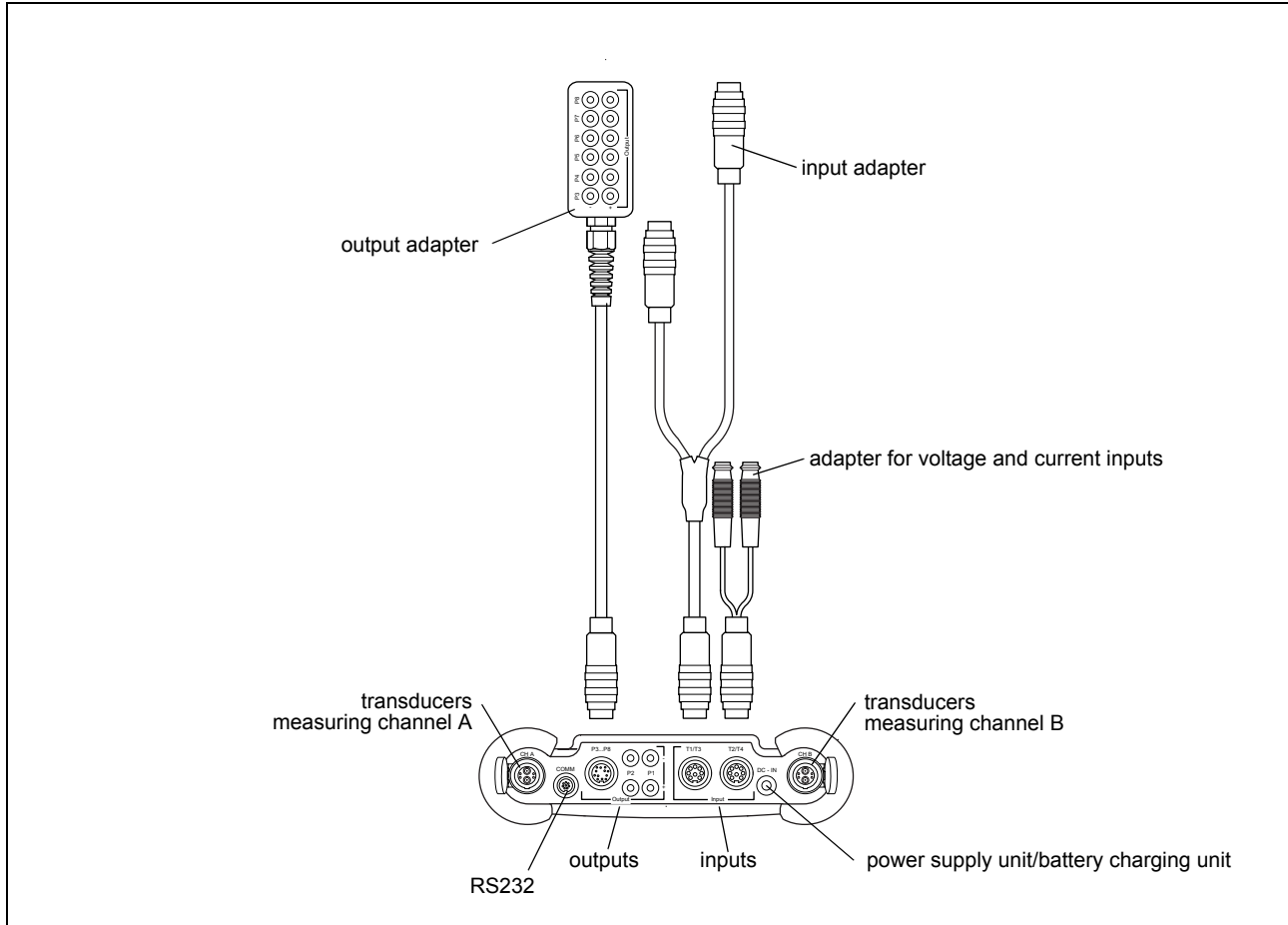

Example for the Equipment of a Transport Case



Transducers

Transducer Selection

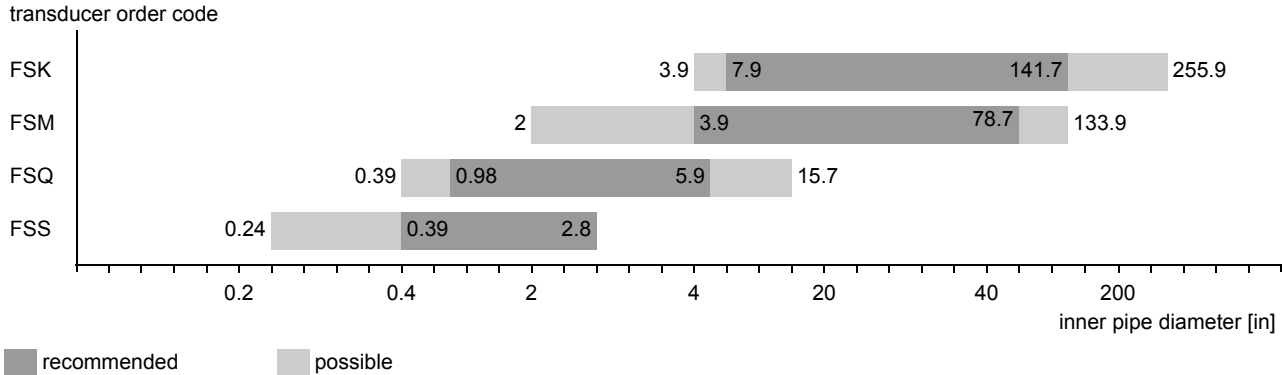

Technical Data
Shear Wave Transducers

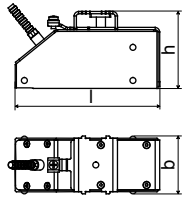
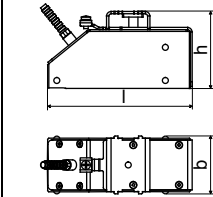
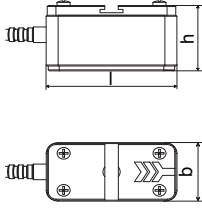
technical type		CDK1NZ7	CLK1NZ7	CDM1NZ7
order code		FSK-NNNNL	FSK-NNNNL/LC	FSM-NNNNL
transducer frequency		MHz 0.5	0.5	1
inner pipe diameter d				
min. extended	in	3.9	3.9	2
min. recommended	in	7.9	7.9	3.9
max. recommended	in	141.7	141.7	78.7
max. extended	in	255.9	255.9	133.9
pipe wall thickness				
min.	in	-	-	-
max.	in	-	-	-
material				
housing		PEEK with stainless steel cap 304	PEEK with stainless steel cap 304	stainless steel 304
contact surface		PEEK	PEEK	PEEK
degree of protection		NEMA 6	NEMA 6	NEMA 6
transducer cable				
type		1699	1699	1699
length	ft	16	29	13
dimensions				
length l	in	4.98	4.98	2.36
width b	in	2.01	2.01	1.18
height h	in	2.66	2.66	1.32
dimensional drawing				
operating temperature				
min.	°F	-40	-40	-40
max.	°F	+266	+266	+266
temperature compensation		x	x	x

Shear Wave Transducers

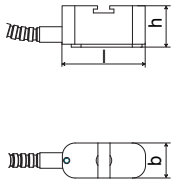
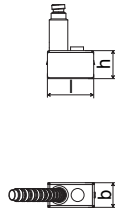
technical type		CDQ1NZ7	CDS1NZ7
order code		FSQ-NNNNL	FSS-NNNNL
transducer frequency	MHz	4	8
inner pipe diameter d			
min. extended	in	0.39	0.24
min. recommended	in	0.98	0.39
max. recommended	in	5.9	2.8
max. extended	in	15.7	2.8
pipe wall thickness			
min.	in	-	-
max.	in	-	-
material			
housing		stainless steel 304	stainless steel 304
contact surface		PEEK	PEI
degree of protection		NEMA 6	NEMA 4
transducer cable			
type		1699	1699
length	ft	9	6
dimensions			
length l	in	1.67	0.98
width b	in	0.71	0.51
height h	in	0.85	0.67
dimensional drawing			
operating temperature			
min.	°F	-40	-22
max.	°F	+266	+266
temperature compensation		x	x

Shear Wave Transducers (extended temperature range)

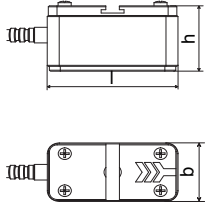
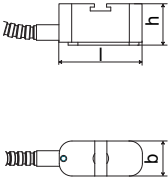
technical type		CDM1EZ7	CDQ1EZ7
order code		FSM-ENNNL	FSQ-ENNNL
transducer frequency	MHz	1	4
inner pipe diameter d			
min. extended	in	2	0.39
min. recommended	in	3.9	0.98
max. recommended	in	78.7	5.9
max. extended	in	133.9	15.7
pipe wall thickness			
min.	in	-	-
max.	in	-	-
material			
housing		stainless steel 304	stainless steel 304
contact surface		Sintimid	Sintimid
degree of protection		NEMA 4	NEMA 4
transducer cable			
type		1699	1699
length	ft	13	9
dimensions			
length l	in	2.36	1.67
width b	in	1.18	0.71
height h	in	1.32	0.85
dimensional drawing			
operating temperature			
min.	°F	-22	-22
max.	°F	+392	+392
temperature compensation		x	x

Transducer Mounting Fixtures

Order Codes

1, 2	3	4	5	6	7 to 9	10, 11	no. of character			
transducer mounting fixture	transducer	-	measuring mode	size	-	fixation	outer pipe diameter	/	option	description
FS										fastening shoes
LM										ladder chain mounting accessory
VP										portable Variofix
TB										tension belts
WL										transducer clamping fixture for Wavelnjector
	A									all transducers
	K									transducers with transducer frequency K
	M									transducers with transducer frequency M
	Q									transducers with transducer frequency Q
	S									transducers with transducer frequency S
			D							reflect mode or diagonal mode
			R							reflect mode
				S						small
				M						medium
						C				chains
						N				without fixation
							L08			0.5 to 8 in
							L22			0.5 to 22 in
							010			0.39 to 3.9 in
							025			0.39 to 9.8 in
							055			0.39 to 21.7 in
							150			2 to 59.1 in
							210			2 to 82.7 in
example										
VP	M	-	D	M	-	C	055			portable Variofix and chains for transducers with transducer frequency M
		-			-			/		

Fastening shoes FS and Chains

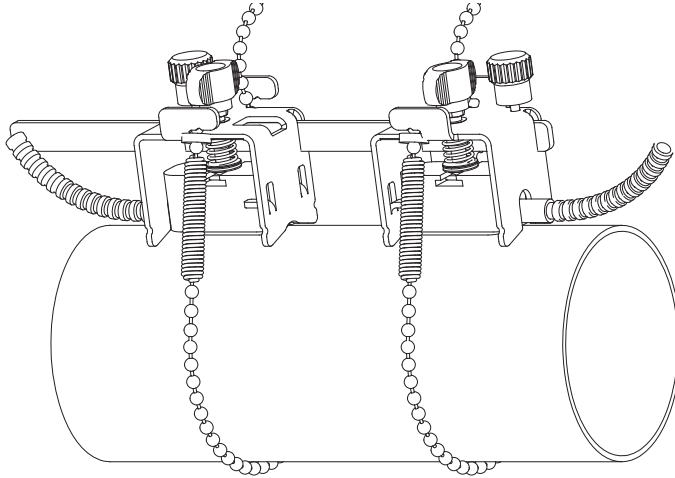

transducer frequency: M, Q

material: stainless steel 304, 301, 303

dimensions:
16.54 x 1.89 x 2.68 in
chain length: 1/3/6 ft
outer pipe diameter:
max. 5.9/12.2/23.6 in

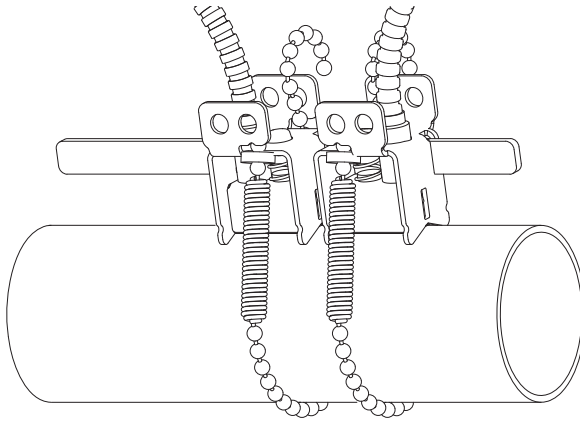

transducer frequency: S

material: stainless steel 304, 301, 303

dimensions:
8.27 x 1.26 x 1.73 in
chain length: 1 ft
outer pipe diameter:
max. 5.9 in

Fastening shoes FS and Magnets (optional)

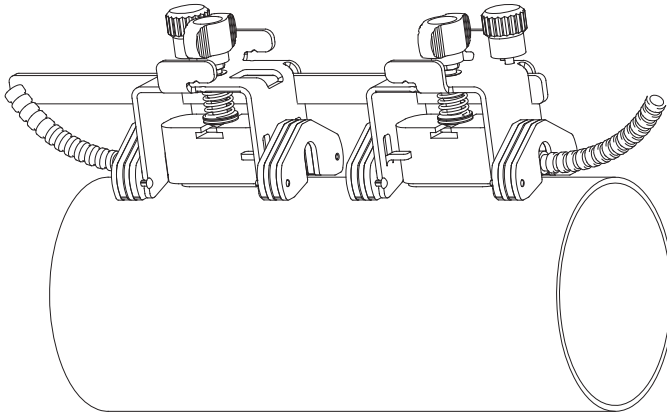

material: stainless steel 304, 301, 303

dimensions:
16.54 x 2.17 x 2.68 in

Ladder Chain Mounting Accessory LM



transducer frequency: M, Q
 chain length: 30/78 in
 outer pipe diameter:
 max. 24 in

Portable Variofix VP and Chains

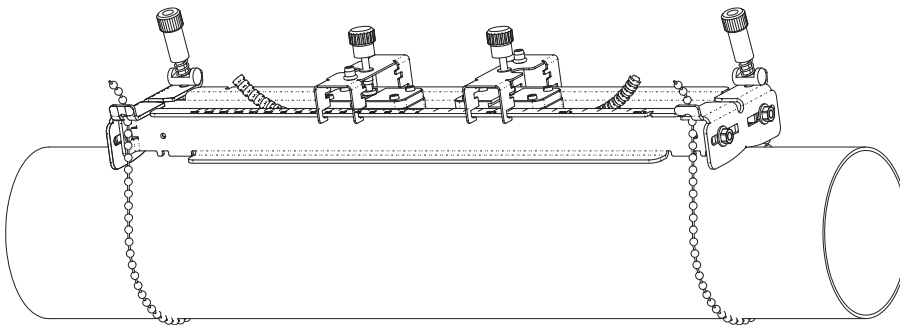

material: stainless steel 304,
 301, 303
 dimensions:
 16.3 x 3.31 x 1.97 in
 chain length: 6 ft

Portable Variofix VP and Magnets (optional)

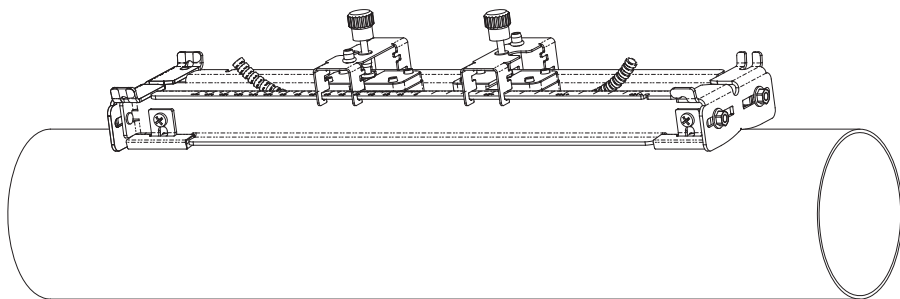

material: stainless steel 304,
 301, 303
 dimensions:
 16.3 x 3.31 x 1.77 in

Tension Belts TB (optional)

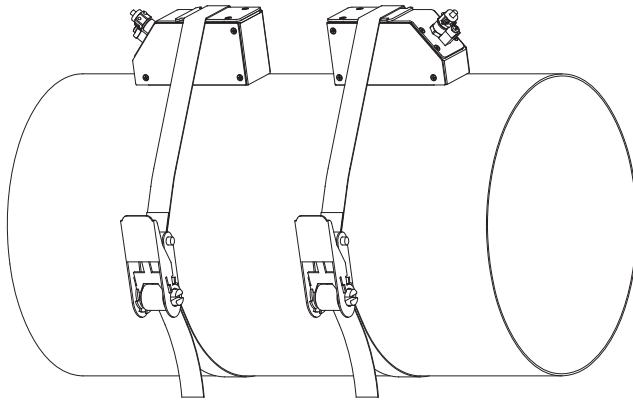

transducer frequency: K

material: steel, powder coated and textile belt

length: 16/22 ft

temperature: max. 140 °F

outer pipe diameter:

max. 59.1/82.7 in

Transducer Clamping Fixture for WavelInjector WL

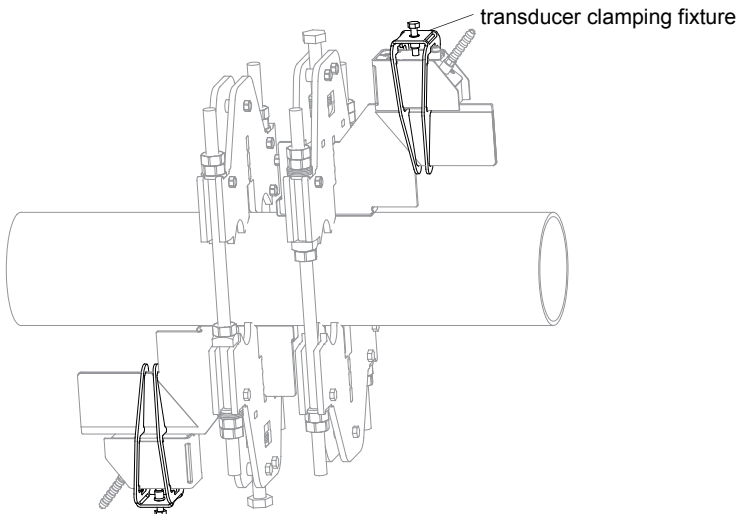

see Technical Specification
TSWavelInjectorVx-x

Coupling Materials for Transducers

	normal temperature range (4th character of transducer order code = N)		extended temperature range (4th character of transducer order code = E)		WaveInjector WI-400	
	< 212 °F	212 to 338 °F	< 302 °F	302 to 392 °F	< 536 °F	536 to 752 °F
< 2 h	coupling compound type N	coupling compound type E	coupling compound type E	coupling compound type E or H	coupling foil type A	coupling foil type B
< 24 h	coupling compound type N	coupling compound type E	coupling compound type E	coupling foil type VT	coupling foil type A	coupling foil type B
< 3 months	coupling compound type N	coupling compound type E	coupling foil type VT	coupling foil type VT	coupling foil type A	coupling foil type B

Technical Data

type	order code	temperature °F	material	remark
coupling compound type N	990739-1	-22 to +266	mineral grease paste	
coupling compound type E	990739-2	-22 to +392	silicone paste	
coupling compound type H	990739-3	-22 to +482	fluoropolymer paste	
coupling foil type A	990739-7	max. 536	Pb	
coupling foil type B	990739-8	> 536 to 752	Ag	
coupling foil type VT	990739-0	14 to 302, short-time peak max. 392	fluoroelastomer	for transducers with transducer frequency G, H, K
	990739-6			for shear wave transducers with transducer frequency M, P
	990739-14			for IP68 shear wave transducers and Lambwave transducers with transducer frequency M, P
	990739-15			for shear wave transducers with transducer frequency Q
	990739-5			for Lambwave transducers with transducer frequency Q

coupling foil not to be used for transducer mounting fixture with magnets

Connection Systems

Connection System NL

transducer frequency (3rd character of transducer order code)		G, H, K			M, P			Q			S		
cable length	ft	x 6	y 9	l ¹ ≤ 82	x 6	y 6	l ¹ ≤ 82	x 6	y 3	l ¹ ≤ 82	x 3	y 3	l ≤ 65

¹ > 82 to 328 f on request

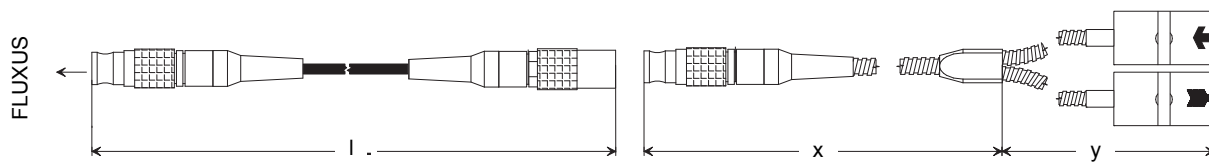

x, y - transducer cable length
l - max. length of extension cable

Transducer Cables

Technical Data

		transducer cable	extension cable
item number		1699	2551
standard length	ft	see table above	16 10
max. length	ft	-	see table above
temperature	°F	-67 to +392	-13 to +176
sheath			
material		stainless steel 304 option OS: 316L	-
outer diameter	in	0.31	-
cable jacket			
material		PTFE	TPE-O
outer diameter	in	0.11	0.31
thickness	in	0.01	
color		brown	black
shield		x	x

Temperature Probes (optional)

Technical Data

order code		670413-1	670412-1	670413-2	670412-2
design				short response time	
type		Pt1000	Pt1000 matched according to DIN 1434-1	Pt1000	Pt1000 matched according to DIN 1434-1
connection		4-wire		4-wire	
measuring range	°F	-22 to +482		-58 to +482	
accuracy T		$\pm(0.27 \text{ }^\circ\text{F} + 2 \cdot 10^{-3} \cdot (T \text{ [}^\circ\text{F]} - 32 \text{ }^\circ\text{F}))$, class A		$\pm(0.27 \text{ }^\circ\text{F} + 2 \cdot 10^{-3} \cdot (T \text{ [}^\circ\text{F]} - 32 \text{ }^\circ\text{F}))$, class A	
accuracy ΔT		-	$\leq 0.1 \text{ K}$ ($3\text{K} < \Delta T < 6 \text{ K}$), more corresponding to EN 1434-1	-	$\leq 0.1 \text{ K}$ ($3\text{K} < \Delta T < 6 \text{ K}$), more corresponding to EN 1434-1
response time	s	50		8	
housing		aluminum		PEEK, stainless steel 304, Cu	
degree of protection		NEMA 4		NEMA 4	
weight (without connector)	lb	0.6	1.1	0.7	1.4
fixation		clamp-on		clamp-on	
accessories		-		plastic protection plate, isolation foam	
dimensions					
length l	in	0.59		0.55	
width b	in	0.59		1.18	
height h	in	0.79		1.06	
dimensional drawing		A	A	B	

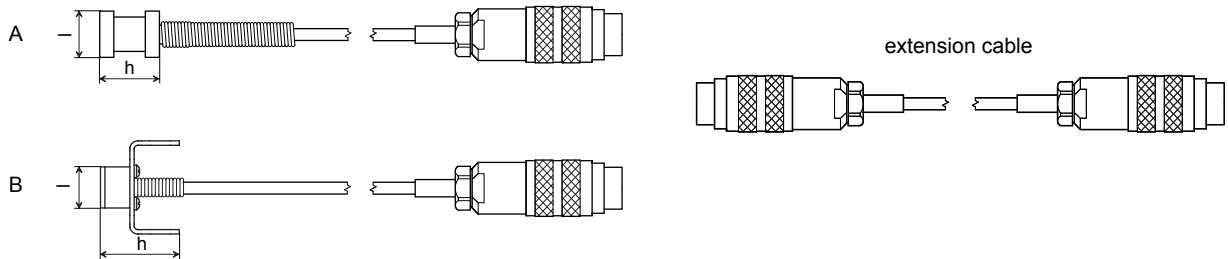

Connection

Temperature Probe

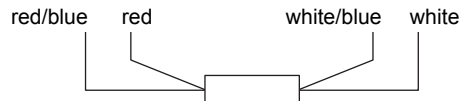

Connector

pin	cable of temperature probe	extension cable
1	white/blue	blue
2	red/blue	gray
3, 4, 5	not connected	
6	red	red
7	white	white
8	not connected	

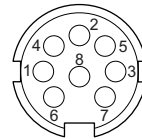

Cables

		cable of temperature probe	extension cable
type		4 x 0.25 mm ² black or white	LIYCY 8 x 0.14 mm ² gray
standard length	ft	9	16/32/82
max. length	ft	-	656
cable jacket		PTFE	PVC

Wall Thickness Probe (optional)

The pipe wall thickness is an important pipe parameter which has to be determined exactly for a good measurement. However, the pipe wall thickness often is unknown.

The wall thickness probe can be connected to the flow transmitter instead of the flow transducers and the wall thickness measurement mode is activated automatically.

Acoustic coupling compound is applied to the wall thickness probe which then is placed firmly on the pipe. The wall thickness is displayed and can be stored directly in the flow transmitter.



Wall thickness measurement

Technical Data

technical type		DWQ1xZ7	DWP1EZ7
		reverse polarity protected	
measuring range ¹	in	0.04 to 7.9	
resolution	in	0.0004	
linearity	in	0.004	
operating temperature	°F	-4 to +140	-4 to +392, short-time peak max. 1004
cable length	ft	4	3

¹ The measuring range depends on the attenuation of the ultrasonic signal in the pipe. For strongly attenuating plastics (e.g. PFA, PTFE, PP) the measuring range is smaller.

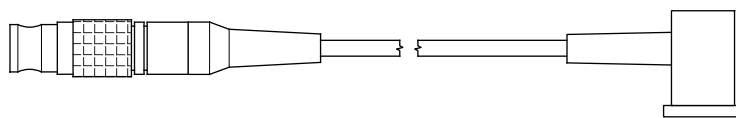

DWQ1xZ7

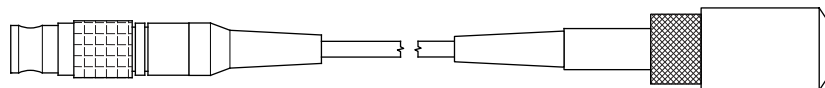

DWP1EZ7



FLEXIM AMERICAS Corporation
Edgewood, NY 11717
USA
Tel.: (631) 492-2300
Fax: (631) 492-2117

internet: www.flexim.com
e-mail: usinfo@flexim.com
1-888-852-7473

Subject to change without notification. Errors excepted.
FLUXUS® is a registered trademark of FLEXIM GmbH.
TSFLUXUS_F601V1-4EN_Lus, 2011-01-13